



KIT, SERVICE, 16K HUSKY-10, SPACER AND HARDWARE

Part # 31804

Dealer / Installer: Provide a copy of these Instructions to the end user of this product. These Instructions provide important operating and safety information for proper usage of this product. Demonstrate the proper use of the product with the end user. Have the end user demonstrate that they understand the proper use of the product.

End User: Read and follow all instructions included in this manual. Ask your Dealer / Installer for assistance if you do not understand the proper use of the product. Never remove any decals from the product.

ITEM NO.	Description	QTY
1	WASHER FLAT .531 ID X 1.062 OD X .095 THK, PREFERRED-TYPE A, NARROW,	2
2	BOLT, HEX HEAD, 1/2-13 X 4.5 LG, GR5, YZ	2
3	NUT, NYLON LOCK, 1/2-13 UNC, GR5, YZ	2
4	HOUSING TO RAIL SPACING ASSEMBLY	1

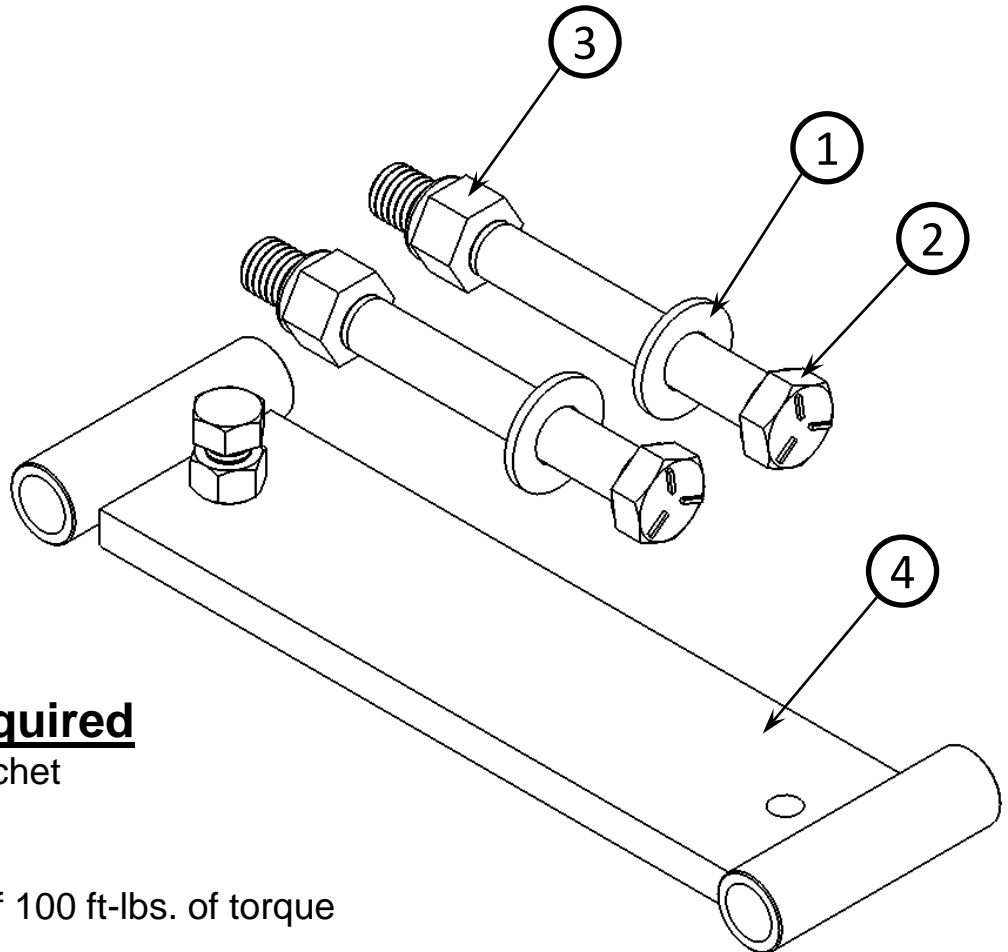

Tools Required

- 3/4" wrench, socket & ratchet
- (2) 9/16" wrenches
- Feeler gauges
- Torque wrench capable of 100 ft-lbs. of torque

Removal

1. Remove 1/2" lock nuts labeled "3"
2. Remove 1/2" hex bolts labeled "2" and washers labeled "1"
3. Spacer assembly should drop from the bottom labeled "4"
4. Discard these parts

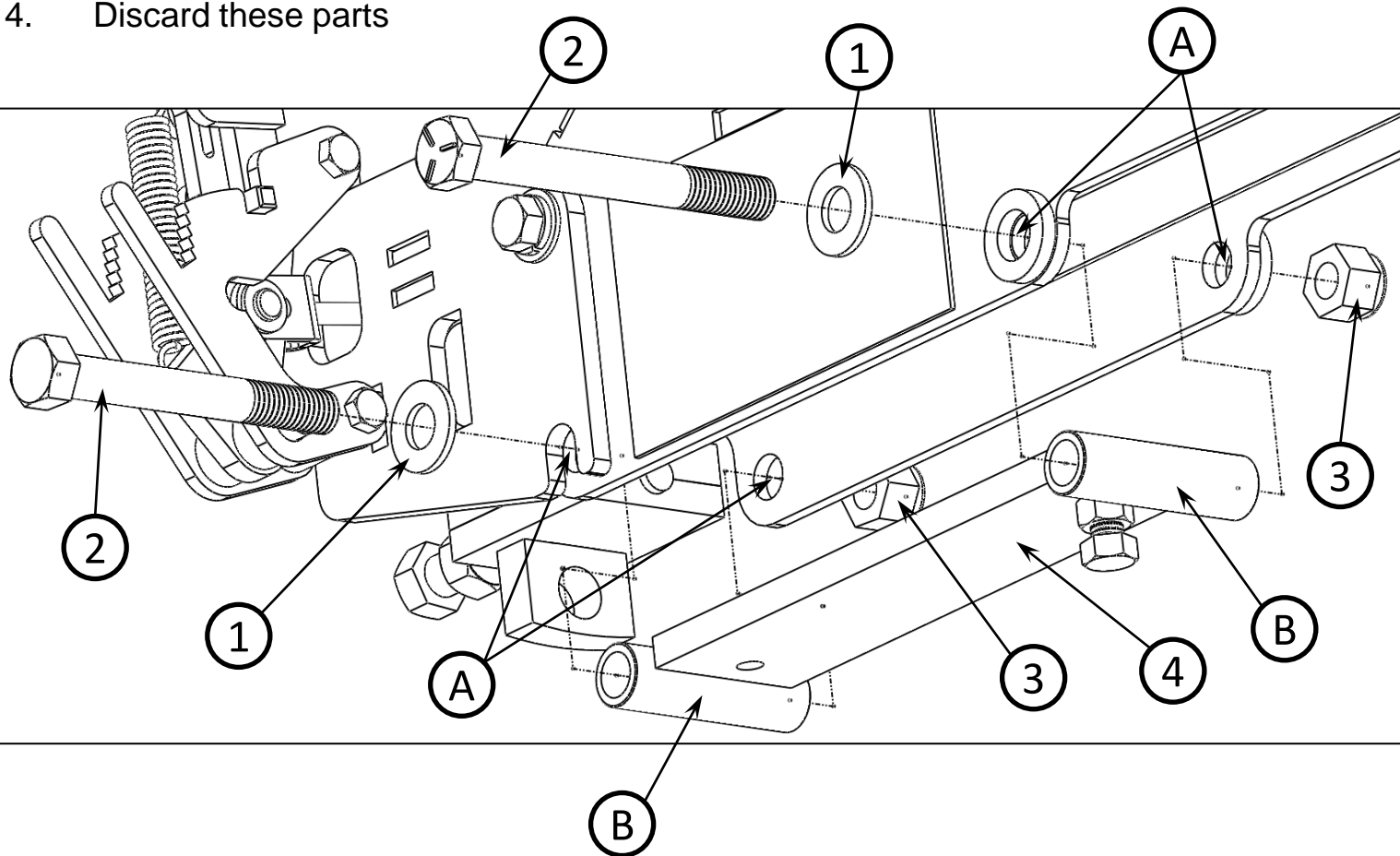

Installation

1. Do not re-use old parts, use new parts supplied in service kit.
2. Install spacer assembly "4" under rail assembly in same orientation as shown above.
3. Place new flat washers "1" onto new hex bolts "2".
4. Insert bolt and washer set through housing holes "A" and bushings "B".
5. Thread lock nuts "3" onto bolts "2" and torque to 75 lbs.-ft.

Bolt Gap Adjustment

1. Loosen lock nut "1".
2. Using feeler gauge, set gap space as shown below.
3. Holding Bolt "2" securely, tighten nut "1" to "jam" bolt in place.
4. Re-check gap.
5. Check the movement of the "16K Husky-10" to ensure movement fore and aft is not hindered.

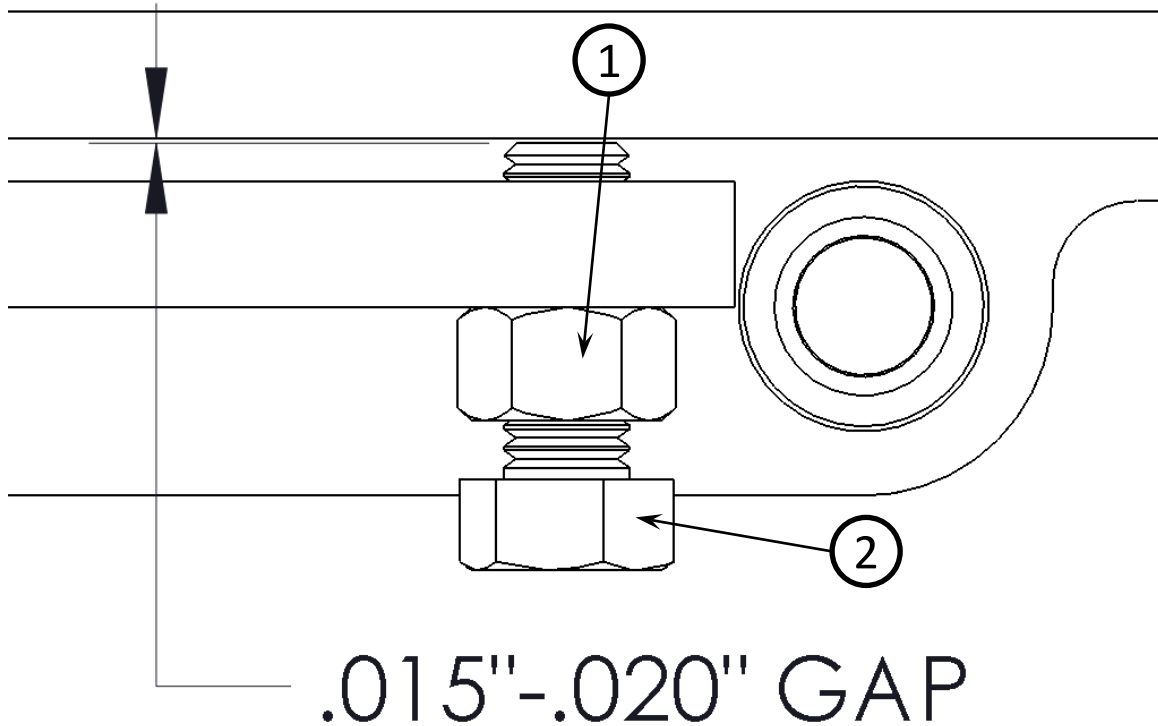

.015"-.020" GAP